

CONTRACT  
FOR  
AS 2024-05 PRE-CAST CONCRETE PIPE AND BRIDGE PRODUCTS  
BETWEEN  
CONTRACTOR AND PENNINGTON COUNTY

THIS CONTRACT, made the 19th day of March, 2024, by and between Rinker Materials, hereinafter called the Contractor, and Pennington County, hereinafter called the County,

WITNESSETH:

The Contractor and the County for the consideration hereinafter named agree as follows:

ARTICLE 1. SCOPE OF WORK

The Contractor shall furnish items as described in the Bid Document and shall do everything required by this Contract, including the following Addendum:

ADDENDUM

DATE

N/A

ARTICLE 2. THE CONTRACT DOCUMENTS

The Notice to Bidders, General Conditions, Specifications and the Proposal form the Contract, and all are as fully a part of the Contract as if hereto attached or herein repeated.

The Contractor further agrees and states they have read the advertisement calling for bids, and have studied the detailed Specifications and are familiar with the terms and conditions stipulated therein.

ARTICLE 3. TIME

Per Specifications.

CONTRACT (CONTINUED)

ARTICLE 4. CONTRACT AMOUNT

Pricing per the attached proposal.

IN WITNESS WHEREOF: Pennington County, its Board of County Commissioners having duly approved this Contract has caused this Contract to be executed in its behalf by its Chair, thereunto duly authorized, attested thereto by its County Auditor, and has hereto attached its corporate seal this 19th day of March, 2024.

PENNINGTON COUNTY OF RAPID CITY,  
SOUTH DAKOTA

BY: [Signature]  
LLOYD LACROIX, CHAIRPERSON  
County

DATE: 4/2/2024

ATTEST:

[Signature]  
CINDY MOHLER,  
County Auditor

(Corporation Seal)



Forterra Concrete Products, LLC DBA Rinker Materials  
NAME OF COMPANY (Contractor)

BY: [Signature]  
AUTHORIZED SIGNATURE

Area Sales Manager  
TITLE

ADDRESS: PO Box 1620

Rapid City, SD 57709-1620

TELEPHONE: 605-718-4111

DATE: March 29, 2024

**PROPOSAL**

**AS 2024-05 PRE-CAST CONCRETE PIPE AND BRIDGE PRODUCTS**

Bidder to supply their own proposal.  
Included within this proposal will be Bidder's  
Federal Tax Identification Number.

**Bidder's Name: Rinker Materials**  
**Address: PO Box 1620, Rapid City, SD 57709-1620**  
**Phone #: 605-718-4111**  
**Federal Tax Identification #: 42-0330890**



# Proposal and / or Contract

## AS 2024-05 PRE-CAST CONCRETE PIPE AND BRIDGE PRODUCTS

### RINKER MATERIALS

PO BOX 1620, RAPID CITY, SD 57709-1620

To The Honorable Board of County Commissioners of PENNINGTON CO.

Honorable Commissioners:

In accordance with the advertisement of the County Auditor inviting proposals for the furnishing of culvert pipe, concrete bridge beams, and/or other materials, the undersigned hereby proposes to furnish Reinforced Concrete Culvert Pipe and other Precast concrete products as follows. All material to be furnished shall conform to the specifications as designated by the South Dakota Highway Department and AASHTO.

BID LETTING TO BE HELD ON MARCH 7, 2024 AT 8:50 AM

SCHEDULE OF PRICES FOR THE PERIOD OF MARCH 19, 2024 Through MARCH 17, 2025

### REINFORCED CONCRETE PIPE

FOB PENNINGTON CO.

SIZE	ROUND PIPE		ARCH PIPE	
	PIPE	END SECTION	PIPE	END SECTION
in	ft	each	ft	each
12" CL5	\$ 24.42	\$ 577.75	\$ -	\$ -
15" CL4	\$ 28.77	\$ 615.82	\$ -	\$ -
18" CL3	\$ 33.77	\$ 876.71	\$ 51.70	\$ 755.04
24" CL3	\$ 42.28	\$ 916.65	\$ 76.79	\$ 855.22
30" CL3	\$ 59.80	\$ 1,234.95	\$ 104.33	\$ 1,237.07
36" CL2	\$ 86.08	\$ 1,544.57	\$ 126.27	\$ 1,615.12
42" CL2	\$ 112.58	\$ 1,732.16	\$ 151.54	\$ 1,879.41
48" CL2	\$ 139.79	\$ 1,974.00	\$ 185.53	\$ 2,119.26
60" CL2	\$ 211.04	\$ 2,557.44	\$ 272.17	\$ 2,779.89
72" CL2	\$ 304.62	\$ 3,422.19	\$ 371.71	\$ 3,684.82
84" CL2	\$ 403.52	\$ 4,366.74	\$ 508.00	\$ 5,224.28
96" CL2	\$ 493.27	\$ -	\$ -	\$ -
108" CL2	\$ 738.51	\$ -	\$ -	\$ -
120" CL2	\$ 1,066.48	\$ -	\$ -	\$ -
4 X 5 CP CL2	\$ 237.20	\$ 2,133.35	\$ -	\$ -
4 X 6 CP CL2	\$ 265.53	\$ 3,746.09	\$ -	\$ -
5 X 7 CP CL2	\$ 365.28	\$ 4,222.79	\$ -	\$ -

3/4" Tie Bolts \$ 37.00 each

1" Tie Bolts \$ 55.60

To convert Class 2 prices to Class 3 prices, add 8% for 36" through 60" round pipe, 36" through 42" arch pipe, and all cattle pass; add 14% for 72" through 84" round pipe and 48" through 84" arch pipe.

Filter fabric, when required, is available in 1' x 300' rolls at \$115.00 per roll.

TERMS: NET 30 DAYS



PROPOSAL: AS 2024-05 PRE-CAST CONCRETE PIPE AND BRIDGE PRODUCTS

RINKER MATERIALS

PO BOX 1620, RAPID CITY, SD 57709-1620  
 PRECAST CONCRETE BOX CULVERTS  
 STRUCTURAL DESIGN BY RINKER MATERIALS

Price FOB PENNINGTON CO.

Size Span X Rise	Length of Section	Weight Each	Barrel Section PLF	End Section Price Each	End Section Length	2' Deep Cutoff Walls Each	9" x 12" Parapets Each
6 X 3	6'-0"	14200	\$ 504.00	\$ 2,908.00	6'	\$ 975.00	\$ 649.00
6 X 4	6'-0"	15400	\$ 530.00	\$ 3,204.00	6'	\$ 975.00	\$ 649.00
6 X 5	6'-0"	16600	\$ 557.00	\$ 5,662.00	10'	\$ 975.00	\$ 649.00
6 X 6	6'-0"	17800	\$ 582.00	\$ 6,172.00	12'	\$ 975.00	\$ 649.00
7 X 3	6'-0"	15400	\$ 539.00	\$ 3,080.00	6'	\$ 1,024.00	\$ 665.00
7 X 4	6'-0"	16600	\$ 560.00	\$ 3,488.00	6'	\$ 1,024.00	\$ 665.00
7 X 5	6'-0"	17800	\$ 601.00	\$ 5,919.00	10'	\$ 1,024.00	\$ 665.00
7 X 6	6'-0"	19000	\$ 623.00	\$ 6,351.00	12'	\$ 1,024.00	\$ 665.00
7 X 7	6'-0"	20200	\$ 640.00	\$ 7,630.00	12'	\$ 1,024.00	\$ 665.00
8 X 4	6'-0"	17800	\$ 626.00	\$ 3,925.00	6'	\$ 1,060.00	\$ 672.00
8 X 5	6'-0"	19000	\$ 641.00	\$ 6,339.00	10'	\$ 1,060.00	\$ 672.00
8 X 6	6'-0"	20200	\$ 667.00	\$ 6,856.00	12'	\$ 1,060.00	\$ 672.00
8 X 7	6'-0"	21400	\$ 699.00	\$ 8,226.00	12'	\$ 1,060.00	\$ 672.00
8 X 8	6'-0"	22600	\$ 732.00	\$ 10,720.00	16'	\$ 1,060.00	\$ 672.00
9 X 4	6'-0"	19400	\$ 602.00	\$ 4,151.00	6'	\$ 1,102.00	\$ 681.00
9 X 5	6'-0"	20600	\$ 634.00	\$ 6,612.00	10'	\$ 1,102.00	\$ 681.00
9 X 6	6'-0"	21900	\$ 671.00	\$ 7,186.00	12'	\$ 1,102.00	\$ 681.00
9 X 7	6'-0"	23100	\$ 700.00	\$ 8,605.00	12'	\$ 1,102.00	\$ 681.00
9 X 8	6'-0"	24300	\$ 735.00	\$ 10,980.00	16'	\$ 1,102.00	\$ 681.00
9 X 9	6'-0"	25600	\$ 779.00	\$ 11,806.00	18'	\$ 1,102.00	\$ 681.00
10 X 4	6'-0"	20700	\$ 681.00	\$ 4,419.00	6'	\$ 1,144.00	\$ 691.00
10 X 5	6'-0"	21900	\$ 714.00	\$ 6,973.00	10'	\$ 1,144.00	\$ 691.00
10 X 6	6'-0"	23100	\$ 749.00	\$ 8,095.00	12'	\$ 1,144.00	\$ 691.00
10 X 7	6'-0"	24300	\$ 768.00	\$ 9,096.00	12'	\$ 1,144.00	\$ 691.00
10 X 8	6'-0"	25500	\$ 803.00	\$ 11,552.00	16'	\$ 1,144.00	\$ 691.00
10 X 9	6'-0"	26700	\$ 842.00	\$ 12,260.00	18'	\$ 1,144.00	\$ 691.00
10 X 10	6'-0"	27900	\$ 877.00	\$ 14,389.00	18'	\$ 1,144.00	\$ 691.00
11 X 4	6'-0"	22900	\$ 752.00	\$ 4,662.00	6'	\$ 1,219.00	\$ 706.00
11 X 5	6'-0"	24150	\$ 777.00	\$ 7,867.00	10'	\$ 1,219.00	\$ 706.00
11 X 6	6'-0"	25400	\$ 818.00	\$ 8,759.00	12'	\$ 1,219.00	\$ 706.00
11 X 7	6'-0"	26600	\$ 844.00	\$ 9,968.00	12'	\$ 1,219.00	\$ 706.00
11 X 8	6'-0"	27900	\$ 879.00	\$ 12,812.00	16'	\$ 1,219.00	\$ 706.00
11 X 9	6'-0"	29100	\$ 909.00	\$ 13,626.00	18'	\$ 1,219.00	\$ 706.00
11 X 10	6'-0"	30350	\$ 944.00	\$ 15,762.00	18'	\$ 1,219.00	\$ 706.00
11 X 11	6'-0"	31600	\$ 1,007.00	\$ 19,083.00	22'	\$ 1,219.00	\$ 706.00

See Page 7 for Necessary Box Culvert Items and Additional Notes

TERMS: NET 30 DAYS



**PROPOSAL: AS 2024-05 PRE-CAST CONCRETE PIPE AND BRIDGE PRODUCTS**

**RINKER MATERIALS**

PO BOX 1620, RAPID CITY, SD 57709-1620  
 PRECAST CONCRETE BOX CULVERTS  
 STRUCTURAL DESIGN BY RINKER MATERIALS

Price FOB PENNINGTON CO.

Size Span X Rise	Length of Section	Weight Each	Barrel Section PLF	End Section Price Each	End Section Length	2' Deep Cutoff Walls Each	9" x 12" Parapets Each
12 X 4	6'-0"	24900	\$ 813.00	\$ 4,910.00	6'	\$ 1,287.00	\$ 721.00
12 X 5	6'-0"	26100	\$ 851.00	\$ 8,246.00	10'	\$ 1,287.00	\$ 721.00
12 X 6	6'-0"	27300	\$ 888.00	\$ 9,284.00	12'	\$ 1,287.00	\$ 721.00
12 X 7	6'-0"	28100	\$ 917.00	\$ 10,475.00	12'	\$ 1,287.00	\$ 721.00
12 X 8	6'-0"	29700	\$ 942.00	\$ 13,302.00	16'	\$ 1,287.00	\$ 721.00
12 X 9	6'-0"	30900	\$ 969.00	\$ 14,200.00	18'	\$ 1,287.00	\$ 721.00
12 X 10	6'-0"	31800	\$ 1,019.00	\$ 16,364.00	20'	\$ 1,287.00	\$ 721.00
12 X 11	6'-0"	33300	\$ 1,079.00	\$ 19,801.00	22'	\$ 1,287.00	\$ 721.00
12 X 12	6'-0"	34500	\$ 1,150.00	\$ 21,084.00	24'	\$ 1,287.00	\$ 721.00
13 X 6	6'-0"	30400	\$ 943.00	\$ 10,001.00	12'	\$ 1,326.00	\$ 729.00
13 X 7	6'-0"	31650	\$ 986.00	\$ 11,563.00	12'	\$ 1,326.00	\$ 729.00
13 X 8	6'-0"	32900	\$ 1,022.00	\$ 14,937.00	16'	\$ 1,326.00	\$ 729.00
13 X 9	6'-0"	34200	\$ 1,068.00	\$ 16,020.00	18'	\$ 1,326.00	\$ 729.00
13 X 10	6'-0"	35400	\$ 1,122.00	\$ 18,339.00	18'	\$ 1,326.00	\$ 729.00
13 X 11	6'-0"	36700	\$ 1,181.00	\$ 21,938.00	22'	\$ 1,326.00	\$ 729.00
13 X 12	6'-0"	37950	\$ 1,247.00	\$ 23,379.00	24'	\$ 1,326.00	\$ 729.00
14 X 4	6'-0"	29500	\$ 899.00	\$ 5,821.00	6'	\$ 1,369.00	\$ 739.00
14 X 5	6'-0"	30800	\$ 933.00	\$ 9,064.00	10'	\$ 1,369.00	\$ 739.00
14 X 6	6'-0"	32000	\$ 961.00	\$ 10,234.00	12'	\$ 1,369.00	\$ 739.00
14 X 7	6'-0"	33300	\$ 1,018.00	\$ 12,054.00	12'	\$ 1,369.00	\$ 739.00
14 X 8	6'-0"	34500	\$ 1,069.00	\$ 15,855.00	16'	\$ 1,369.00	\$ 739.00
14 X 9	6'-0"	37500	\$ 1,145.00	\$ 17,037.00	18'	\$ 1,369.00	\$ 739.00
14 X 10	6'-0"	38900	\$ 1,206.00	\$ 19,858.00	18'	\$ 1,369.00	\$ 739.00
14 X 11	6'-0"	40300	\$ 1,264.00	\$ 23,425.00	22'	\$ 1,369.00	\$ 739.00
14 X 12	6'-0"	41700	\$ 1,317.00	\$ 24,894.00	24'	\$ 1,369.00	\$ 739.00
14 X 13	6'-0"	43200	\$ 1,383.00	\$ 27,204.00	24'	\$ 1,369.00	\$ 739.00
14 X 14	6'-0"	44600	\$ 1,436.00	\$ 31,562.00	28'	\$ 1,369.00	\$ 739.00

**See Page 7 for Necessary Box Culvert Items and Additional Notes**

TERMS: NET 30 DAYS



**PROPOSAL: AS 2024-05 PRE-CAST CONCRETE PIPE AND BRIDGE PRODUCTS**

**RINKER MATERIALS**

PO BOX 1620, RAPID CITY, SD 57709-1620  
 PRECAST CONCRETE BOX CULVERTS  
 STRUCTURAL DESIGN BY RINKER MATERIALS

Price FOB PENNINGTON CO.

Size Span X Rise	Length of Section	Weight Each	Barrel Section PLF	End Section Price Each	End Section Length	2' Deep Cutoff Walls Each	9" x 12" Parapets Each
15 X 4	6'-0"	32000	\$ 1,212.00	\$ 6,310.00	6'	\$ 1,428.00	\$ 781.00
15 X 5	6'-0"	33300	\$ 1,243.00	\$ 9,607.00	10'	\$ 1,428.00	\$ 781.00
15 X 6	6'-0"	34600	\$ 1,278.00	\$ 11,607.00	12'	\$ 1,428.00	\$ 781.00
15 X 7	6'-0"	36000	\$ 1,308.00	\$ 12,289.00	12'	\$ 1,428.00	\$ 781.00
15 X 8	6'-0"	37400	\$ 1,360.00	\$ 16,412.00	16'	\$ 1,428.00	\$ 781.00
15 X 9	6'-0"	40000	\$ 1,417.00	\$ 19,562.00	18'	\$ 1,428.00	\$ 781.00
15 X 10	6'-0"	42500	\$ 1,467.00	\$ 20,600.00	18'	\$ 1,428.00	\$ 781.00
15 X 11	6'-0"	44400	\$ 1,515.00	\$ 24,274.00	22'	\$ 1,428.00	\$ 781.00
15 X 12	6'-0"	46300	\$ 1,562.00	\$ 28,536.00	24'	\$ 1,428.00	\$ 781.00
15 X 13	6'-0"	48200	\$ 1,610.00	\$ 30,276.00	24'	\$ 1,428.00	\$ 781.00
15 X 14	6'-0"	50000	\$ 1,659.00	\$ 35,135.00	28'	\$ 1,428.00	\$ 781.00
16 X 4	6'-0"	36500	\$ 1,309.00	\$ 6,645.00	6'	\$ 1,511.00	\$ 830.00
16 X 5	6'-0"	37835	\$ 1,341.00	\$ 10,355.00	10'	\$ 1,511.00	\$ 830.00
16 X 6	6'-0"	39165	\$ 1,370.00	\$ 12,542.00	12'	\$ 1,511.00	\$ 830.00
16 X 7	6'-0"	40500	\$ 1,400.00	\$ 13,226.00	12'	\$ 1,511.00	\$ 830.00
16 X 8	6'-0"	42325	\$ 1,443.00	\$ 17,266.00	16'	\$ 1,511.00	\$ 830.00
16 X 9	6'-0"	44160	\$ 1,486.00	\$ 20,719.00	18'	\$ 1,511.00	\$ 830.00
16 X 10	6'-0"	46000	\$ 1,529.00	\$ 21,863.00	18'	\$ 1,511.00	\$ 830.00
16 X 11	6'-0"	48125	\$ 1,584.00	\$ 26,469.00	22'	\$ 1,511.00	\$ 830.00
16 X 12	6'-0"	50250	\$ 1,639.00	\$ 29,538.00	24'	\$ 1,511.00	\$ 830.00
16 X 13	6'-0"	52375	\$ 1,696.00	\$ 32,699.00	24'	\$ 1,511.00	\$ 830.00
16 X 14	6'-0"	54500	\$ 1,756.00	\$ 37,967.00	28'	\$ 1,511.00	\$ 830.00
17 X 4	6'-0"	42000	\$ 1,348.00	\$ 7,886.00	6'	\$ 1,595.00	\$ 882.00
17 X 5	6'-0"	42650	\$ 1,360.00	\$ 12,315.00	10'	\$ 1,595.00	\$ 882.00
17 X 6	6'-0"	43300	\$ 1,383.00	\$ 15,043.00	12'	\$ 1,595.00	\$ 882.00
17 X 7	6'-0"	44500	\$ 1,425.00	\$ 16,071.00	12'	\$ 1,595.00	\$ 882.00
17 X 8	6'-0"	45700	\$ 1,458.00	\$ 19,846.00	16'	\$ 1,595.00	\$ 882.00
17 X 9	6'-0"	49350	\$ 1,575.00	\$ 23,614.00	18'	\$ 1,595.00	\$ 882.00
17 X 10	6'-0"	53000	\$ 1,668.00	\$ 24,886.00	18'	\$ 1,595.00	\$ 882.00
17 X 11	6'-0"	54500	\$ 1,727.00	\$ 30,133.00	22'	\$ 1,595.00	\$ 882.00
17 X 12	6'-0"	56000	\$ 1,784.00	\$ 33,598.00	24'	\$ 1,595.00	\$ 882.00

See Page 7 for Necessary Box Culvert Items and Additional Notes

TERMS: NET 30 DAYS



**PROPOSAL: AS 2024-05 PRE-CAST CONCRETE PIPE AND BRIDGE PRODUCTS**

**RINKER MATERIALS**

PO BOX 1620, RAPID CITY, SD 57709-1620  
 PRECAST CONCRETE BOX CULVERTS  
 STRUCTURAL DESIGN BY RINKER MATERIALS

Price FOB PENNINGTON CO.

Size Span X Rise	Length of Section	Weight Each	Barrel Section PLF	End Section Price Each	End Section Length	2' Deep Cutoff Walls Each	9" x 12" Parapets Each
18 X 5	6'-0"	48100	\$ 1,515.00	\$ 13,517.00	10'	\$ 1,677.00	\$ 934.00
18 X 6	6'-0"	49050	\$ 1,546.00	\$ 15,452.00	12'	\$ 1,677.00	\$ 934.00
18 X 7	6'-0"	50000	\$ 1,636.00	\$ 16,321.00	12'	\$ 1,677.00	\$ 934.00
18 X 8	6'-0"	54500	\$ 1,788.00	\$ 22,872.00	16'	\$ 1,677.00	\$ 934.00
18 X 9	6'-0"	56500	\$ 1,854.00	\$ 26,314.00	18'	\$ 1,677.00	\$ 934.00
18 X 10	5'-0"	48500	\$ 2,019.00	\$ 27,859.00	18'	\$ 1,677.00	\$ 934.00
18 X 11	5'-0"	50200	\$ 2,093.00	\$ 33,738.00	22'	\$ 1,677.00	\$ 934.00
18 X 12	5'-0"	51800	\$ 2,157.00	\$ 37,689.00	24'	\$ 1,677.00	\$ 934.00
19 X 4	6'-0"	53500	\$ 1,676.00	\$ 9,446.00	6'	\$ 1,763.00	\$ 986.00
19 X 5	6'-0"	55800	\$ 1,745.00	\$ 14,770.00	10'	\$ 1,763.00	\$ 986.00
19 X 6	6'-0"	48800	\$ 1,637.00	\$ 15,836.00	12'	\$ 1,763.00	\$ 986.00
19 X 7	6'-0"	50450	\$ 1,690.00	\$ 16,900.00	12'	\$ 1,763.00	\$ 986.00
19 X 8	6'-0"	52100	\$ 1,745.00	\$ 22,070.00	16'	\$ 1,763.00	\$ 986.00
19 X 9	5'-0"	48600	\$ 1,959.00	\$ 26,623.00	18'	\$ 1,763.00	\$ 986.00
19 X 10	5'-0"	50000	\$ 2,014.00	\$ 27,933.00	18'	\$ 1,763.00	\$ 986.00
19 X 11	5'-0"	53500	\$ 2,153.00	\$ 32,256.00	22'	\$ 1,763.00	\$ 986.00
20 X 4	6'-0"	54550	\$ 1,729.00	\$ 9,570.00	6'	\$ 1,845.00	\$ 1,037.00
20 X 5	6'-0"	56200	\$ 1,805.00	\$ 14,971.00	10'	\$ 1,845.00	\$ 1,037.00
20 X 6	6'-0"	48950	\$ 1,667.00	\$ 18,011.00	12'	\$ 1,845.00	\$ 1,037.00
20 X 7	6'-0"	50950	\$ 1,690.00	\$ 18,598.00	12'	\$ 1,845.00	\$ 1,037.00
20 X 8	6'-0"	52400	\$ 1,745.00	\$ 23,768.00	16'	\$ 1,845.00	\$ 1,037.00
20 X 9	6'-0"	53900	\$ 1,805.00	\$ 27,163.00	18'	\$ 1,845.00	\$ 1,037.00
20 X 10	5'-0"	57500	\$ 2,262.00	\$ 29,170.00	18'	\$ 1,845.00	\$ 1,037.00

**See Page 7 for Necessary Box Culvert Items and Additional Notes**

TERMS: NET 30 DAYS

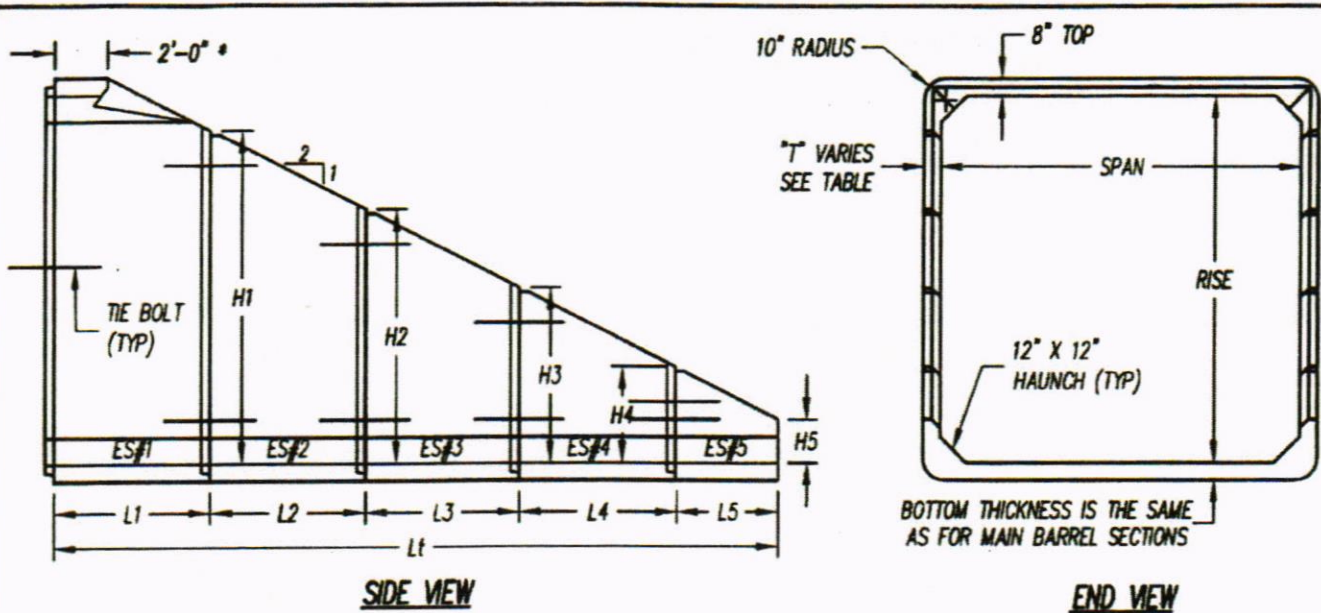

\* WHERE NO END SECTION #1 IS PROVIDED - ADD 2'-0" TO LENGTH OF FULL BBL SECTIONS FOR EACH TYPE-1 END

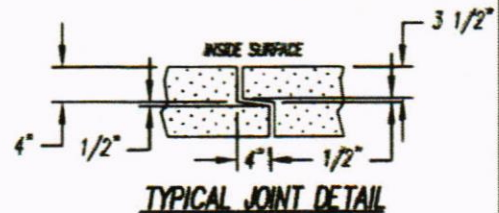

RISE	Lt	L1	L2	L3	L4	L5	H1	H2	H3	H4	H5	T
ft	ft	ft-in	ft-in	ft-in	ft-in	ft-in	ft-in	ft-in	ft-in	ft-in	ft-in	ft
3	6	6-0	--	--	--	--	1-8	--	--	--	--	8
3' RISE AVAILABLE ONLY ON 6'-0" AND 7'-0" SPANS												
4 *	6	--	6-0	--	--	--	4-8	1-8	--	--	--	8
5	10	6-0	4-0	--	--	--	3-8	1-8	--	--	--	8
6	12	6-0	6-0	--	--	--	4-8	1-8	--	--	--	8
7 *	12	--	6-0	6-0	--	--	7-8	4-8	1-8	--	--	8
8	16	6-0	6-0	4-0	--	--	6-8	3-8	1-8	--	--	8
9	18	6-0	6-0	6-0	--	--	7-8	4-8	1-8	--	--	8
10 *	18	--	6-0	6-0	6-0	--	10-8	7-8	4-8	1-8	--	8
11	22	6-0	6-0	6-0	4-0	--	9-8	6-8	3-8	1-8	--	8
12	24	6-0	6-0	6-0	6-0	--	10-8	7-8	4-8	1-8	--	8
13 *	24	--	6-0	6-0	6-0	6-0	13-8	10-8	7-8	4-8	1-8	10
14	28	6-0	6-0	6-0	6-0	4-0	12-8	9-8	6-8	3-8	1-8	9

- End sections have same full joint as the full barrel section. The joint on end section pieces #1, #2, #3, #4 and #5 of the outlet end have the joint reversed to facilitate construction.
- Each individual section weighs less than full barrel section.
- All 6'-0" end section lengths are available upon request.
- Reinforcing design will be provided for each end section.

**Rinker**  
MATERIALS™  
A QUIKRETE® COMPANY

Rapid City, South Dakota  
4310 Pendleton Drive  
Rapid City, SD 57701  
(805) 718-4111

SCALE: NONE PROJECT: SINGLE CELL BOX CULVERT TYPE-1 SLOPED END SECTIONS

DATE: 6/3/04

DR'N BY: RTF

REV: 2/2/16 REM DWG NAME: 1810-10

PROPRIETARY & CONFIDENTIAL: INFORMATION PROVIDED IS THE PROPERTY OF RINKER MATERIALS. UNAUTHORIZED REPRODUCTION IS PROHIBITED.



PROPOSAL: AS 2024-05 PRE-CAST CONCRETE PIPE AND BRIDGE PRODUCTS

**RINKER MATERIALS**

PO BOX 1620, RAPID CITY, SD 57709-1620  
 DOUBLE CELL PRECAST CONCRETE BOX CULVERTS  
 RINKER MATERIALS CONCRETE DESIGN

Price FOB PENNINGTON CO.

Size Span X Rise	Length of Section	Weight Each	Barrell Section PLF	End Section Price Each	End Section Length	2' Deep Cutoff Walls Each	9" x 12" Parapets Each
DBL 7 X 3	6'-0"	28100	\$ 964.00	\$ 5,449.00	6'	\$ 1,439.00	\$ 1,025.00
DBL 7 X 4	6'-0"	29900	\$ 992.00	\$ 6,404.00	6'	\$ 1,439.00	\$ 1,025.00
DBL 7 X 5	6'-0"	31800	\$ 1,022.00	\$ 10,146.00	10'	\$ 1,439.00	\$ 1,025.00
DBL 7 X 6	6'-0"	33700	\$ 1,064.00	\$ 12,077.00	12'	\$ 1,439.00	\$ 1,025.00
DBL 7 X 7	6'-0"	35500	\$ 1,099.00	\$ 13,385.00	12'	\$ 1,439.00	\$ 1,025.00
DBL 8 X 4	6'-0"	32400	\$ 1,038.00	\$ 7,379.00	6'	\$ 1,553.00	\$ 1,050.00
DBL 8 X 5	6'-0"	34300	\$ 1,076.00	\$ 10,559.00	10'	\$ 1,553.00	\$ 1,050.00
DBL 8 X 6	6'-0"	36200	\$ 1,126.00	\$ 11,746.00	12'	\$ 1,553.00	\$ 1,050.00
DBL 8 X 7	6'-0"	38100	\$ 1,181.00	\$ 14,124.00	12'	\$ 1,553.00	\$ 1,050.00
DBL 8 X 8	6'-0"	39900	\$ 1,216.00	\$ 17,624.00	16'	\$ 1,553.00	\$ 1,050.00
DBL 9 X 4	6'-0"	34900	\$ 1,119.00	\$ 8,065.00	6'	\$ 1,633.00	\$ 1,081.00
DBL 9 X 5	6'-0"	36800	\$ 1,155.00	\$ 11,787.00	10'	\$ 1,633.00	\$ 1,081.00
DBL 9 X 6	6'-0"	38700	\$ 1,195.00	\$ 12,387.00	12'	\$ 1,633.00	\$ 1,081.00
DBL 9 X 7	6'-0"	40600	\$ 1,239.00	\$ 14,592.00	12'	\$ 1,633.00	\$ 1,081.00
DBL 9 X 8	6'-0"	42500	\$ 1,267.00	\$ 18,316.00	16'	\$ 1,633.00	\$ 1,081.00
DBL 9 X 9	6'-0"	44400	\$ 1,307.00	\$ 19,357.00	18'	\$ 1,633.00	\$ 1,081.00
DBL 10 X 4	6'-0"	37400	\$ 1,218.00	\$ 8,512.00	6'	\$ 1,764.00	\$ 1,094.00
DBL 10 X 5	6'-0"	39300	\$ 1,258.00	\$ 11,635.00	10'	\$ 1,764.00	\$ 1,094.00
DBL 10 X 6	6'-0"	41200	\$ 1,296.00	\$ 13,588.00	12'	\$ 1,764.00	\$ 1,094.00
DBL 10 X 7	6'-0"	44880	\$ 1,342.00	\$ 15,554.00	12'	\$ 1,764.00	\$ 1,094.00
DBL 10 X 8	6'-0"	46800	\$ 1,381.00	\$ 19,510.00	16'	\$ 1,764.00	\$ 1,094.00
DBL 10 X 9	6'-0"	48720	\$ 1,427.00	\$ 20,601.00	18'	\$ 1,764.00	\$ 1,094.00
DBL 10 X 10	6'-0"	50640	\$ 1,483.00	\$ 23,841.00	18'	\$ 1,764.00	\$ 1,094.00
DBL 11 X 4	6'-0"	45600	\$ 1,389.00	\$ 9,275.00	6'	\$ 1,923.00	\$ 1,121.00
DBL 11 X 5	6'-0"	47580	\$ 1,428.00	\$ 13,473.00	10'	\$ 1,923.00	\$ 1,121.00
DBL 11 X 6	6'-0"	49500	\$ 1,471.00	\$ 14,671.00	12'	\$ 1,923.00	\$ 1,121.00
DBL 11 X 7	6'-0"	51120	\$ 1,528.00	\$ 16,987.00	12'	\$ 1,923.00	\$ 1,121.00
DBL 11 X 8	6'-0"	53370	\$ 1,574.00	\$ 21,018.00	16'	\$ 1,923.00	\$ 1,121.00
DBL 11 X 9	6'-0"	55320	\$ 1,617.00	\$ 22,298.00	18'	\$ 1,923.00	\$ 1,121.00
DBL 11 X 10	6'-0"	57240	\$ 1,660.00	\$ 25,455.00	18'	\$ 1,923.00	\$ 1,121.00
DBL 11 X 11	5'-0"	51800	\$ 1,714.00	\$ 29,785.00	22'	\$ 1,923.00	\$ 1,121.00

See Page 7 for Necessary Box Culvert Items and Additional Notes

TERMS: NET 30 DAYS



**PROPOSAL: AS 2024-05 PRE-CAST CONCRETE PIPE AND BRIDGE PRODUCTS**

**RINKER MATERIALS**

PO BOX 1620, RAPID CITY, SD 57709-1620  
 DOUBLE CELL PRECAST CONCRETE BOX CULVERTS  
 RINKER MATERIALS CONCRETE DESIGN

Price FOB PENNINGTON CO.

Size Span X Rise	Length of Section	Weight Each	Barrell Section PLF	End Section Price Each	End Section Length	2' Deep Cutoff Walls Each	9' x 12" Parapets Each
DBL 12 X 4	6'-0"	48720	\$ 1,452.00	\$ 9,413.00	6'	\$ 2,057.00	\$ 1,141.00
DBL 12 X 5	6'-0"	50640	\$ 1,503.00	\$ 13,721.00	10'	\$ 2,057.00	\$ 1,141.00
DBL 12 X 6	6'-0"	52560	\$ 1,544.00	\$ 15,148.00	12'	\$ 2,057.00	\$ 1,141.00
DBL 12 X 7	6'-0"	54480	\$ 1,593.00	\$ 20,186.00	12'	\$ 2,057.00	\$ 1,141.00
DBL 12 X 8	6'-0"	56400	\$ 1,634.00	\$ 21,894.00	16'	\$ 2,057.00	\$ 1,141.00
DBL 12 X 9	6'-0"	58380	\$ 1,681.00	\$ 23,218.00	18'	\$ 2,057.00	\$ 1,141.00
DBL 12 X 10	5'-0"	51600	\$ 1,728.00	\$ 29,077.00	18'	\$ 2,057.00	\$ 1,141.00
DBL 12 X 11	5'-0"	55700	\$ 1,784.00	\$ 30,753.00	22'	\$ 2,057.00	\$ 1,141.00
DBL 12 X 12	5'-0"	57500	\$ 1,819.00	\$ 31,863.00	24'	\$ 2,057.00	\$ 1,141.00
DBL 14 X 4	6'-0"	57300	\$ 1,704.00	\$ 11,196.00	6'	\$ 2,401.00	\$ 1,304.00
DBL 14 X 5	6'-0"	59220	\$ 1,739.00	\$ 15,550.00	10'	\$ 2,401.00	\$ 1,304.00
DBL 14 X 6	5'-0"	51000	\$ 1,785.00	\$ 17,025.00	12'	\$ 2,401.00	\$ 1,304.00
DBL 14 X 7	5'-0"	54200	\$ 1,904.00	\$ 22,308.00	12'	\$ 2,401.00	\$ 1,304.00
DBL 14 X 8	5'-0"	55800	\$ 1,947.00	\$ 25,915.00	16'	\$ 2,401.00	\$ 1,304.00
DBL 14 X 9	5'-0"	57450	\$ 1,997.00	\$ 27,865.00	18'	\$ 2,401.00	\$ 1,304.00
DBL 14 X 10	4'-0"	48400	\$ 2,053.00	\$ 34,466.00	18'	\$ 2,401.00	\$ 1,304.00
DBL 14 X 11	4'-0"	51600	\$ 2,094.00	\$ 37,379.00	22'	\$ 2,401.00	\$ 1,304.00
DBL 14 X 12	4'-0"	53200	\$ 2,141.00	\$ 39,503.00	24'	\$ 2,401.00	\$ 1,304.00
DBL 14 X 13	4'-0"	56800	\$ 2,296.00	\$ 46,236.00	24'	\$ 2,401.00	\$ 1,304.00
DBL 14 X 14	4'-0"	58600	\$ 2,335.00	\$ 49,268.00	28'	\$ 2,401.00	\$ 1,304.00
DBL 15 X 5	4'-0"	49500	\$ 2,354.00	\$ 20,620.00	10'	\$ 2,776.00	\$ 1,663.00
DBL 15 X 6	4'-0"	50250	\$ 2,485.00	\$ 22,840.00	12'	\$ 2,776.00	\$ 1,663.00
DBL 15 X 7	4'-0"	51700	\$ 2,685.00	\$ 23,305.00	12'	\$ 2,776.00	\$ 1,663.00
DBL 15 X 8	4'-0"	54000	\$ 2,705.00	\$ 33,877.00	16'	\$ 2,776.00	\$ 1,663.00
DBL 15 X 9	4'-0"	55375	\$ 2,771.00	\$ 38,661.00	18'	\$ 2,776.00	\$ 1,663.00
DBL 15 X 10	4'-0"	57150	\$ 2,837.00	\$ 40,390.00	18'	\$ 2,776.00	\$ 1,663.00
DBL 15 X 11	4'-0"	58525	\$ 2,902.00	\$ 48,785.00	22'	\$ 2,776.00	\$ 1,663.00
DBL 15 X 12	4'-0"	59500	\$ 2,967.00	\$ 54,156.00	24'	\$ 2,776.00	\$ 1,663.00

- 1.) If reinforcing steel costs rise over \$1.00/lb., Rinker Materials reserves the right to add a steel surcharge.
- 2.) The above prices are for furnishing Precast Box Culverts designed for HL-93 and Alternate live load with fill heights ranging from 0' - 10' of cover.
- 3.) Alternate style End Sections available upon request.
- 4.) Box culverts over 14' wide will require a separate haul quote.

**Misc. Box Culvert Items**

Joint Sealant (1.00" X 14.5')	\$ 24.20 /EA
Galvanized Tie Bolt	\$ 81.80 /EA
Joint Fabric (2.5' x 360' Roll)	\$ 200.10 /EA
9"X9" EDM Lift Hole Covers	\$ 4.50 /EA
Set Grout (.5 Cu Ft.)	\$ 30.00 /EA
Pourable Epoxy (1 Gallon)	\$ 277.50 /EA
Fence Anchor Assembly	\$ 57.80 /EA
#4X12" Epoxy Dowel	\$ 4.30 /EA

TERMS: NET 30 DAYS



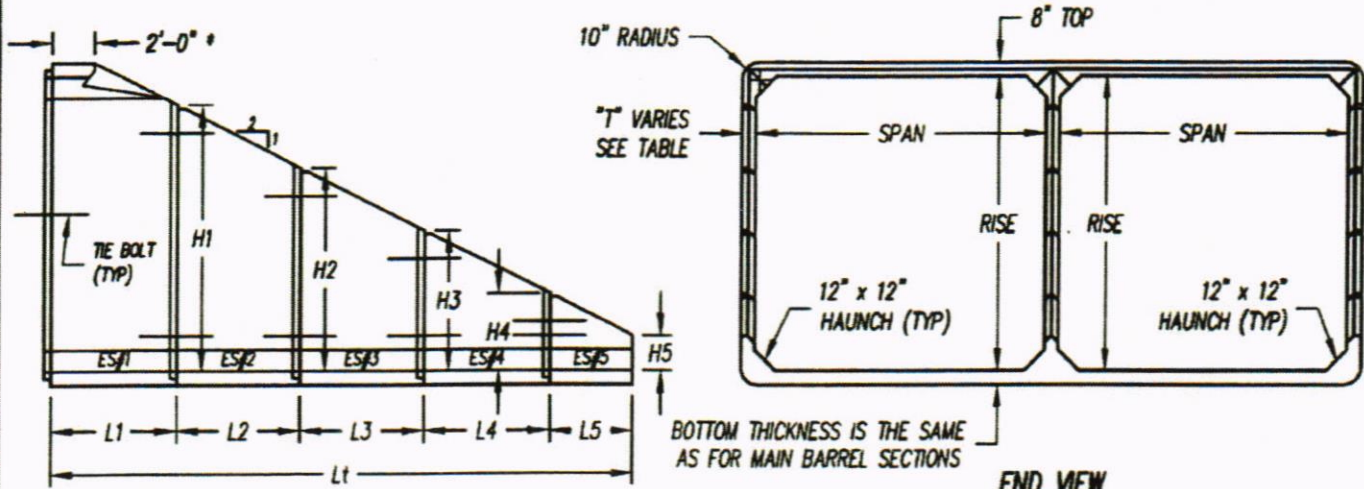

**SIDE VIEW**

**END VIEW**

\* WHERE NO END SECTION #1 IS PROVIDED - ADD 2'-0" TO LENGTH OF FULL BBL SECTIONS FOR EACH TYPE-1 END

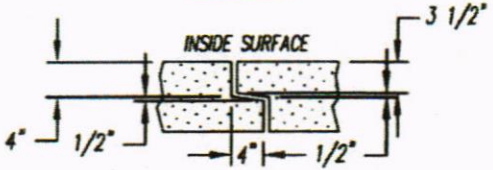

**TYPICAL JOINT DETAIL**

RISE	Lt	L1	L2	L3	L4	L5	H1	H2	H3	H4	H5	T
ft	ft	ft-in	ft-in	ft-in	ft-in	ft-in	ft-in	ft-in	ft-in	ft-in	ft-in	ft
3	6	6-0	--	--	--	--	1-8	--	--	--	--	8
3' RISE AVAILABLE ONLY ON 7'-0" SPANS												
4 *	6	--	6-0	--	--	--	4-8	1-8	--	--	--	8
5	10	6-0	4-0	--	--	--	3-8	1-8	--	--	--	8
6	12	6-0	6-0	--	--	--	4-8	1-8	--	--	--	8
7 *	12	--	6-0	6-0	--	--	7-8	4-8	1-8	--	--	8
8	16	6-0	6-0	4-0	--	--	6-8	3-8	1-8	--	--	8
9	18	6-0	6-0	6-0	--	--	7-8	4-8	1-8	--	--	8
10 *	18	--	6-0	6-0	6-0	--	10-8	7-8	4-8	1-8	--	8
11	22	6-0	6-0	6-0	4-0	--	9-8	6-8	3-8	1-8	--	8
12	24	6-0	6-0	6-0	6-0	--	10-8	7-8	4-8	1-8	--	8
13 *	24	--	6-0	6-0	6-0	6-0	13-8	10-8	7-8	4-8	1-8	10
14	28	6-0	6-0	6-0	6-0	4-0	12-8	9-8	6-8	3-8	1-8	9

- End sections have same full joint as the full barrel section. The joint on end section pieces #1, #2, #3, #4 and #5 of the outlet end have the joint reversed to facilitate construction.
- Each individual section weighs less than full barrel section.
- All 6'-0" end section lengths are available upon request.
- Reinforcing design will be provided for each end section.

**Rinker**  
MATERIALS™  
A QUINCY™ COMPANY

Rapid City, South Dakota  
4310 Pendleton Drive  
Rapid City, SD 57701  
(605) 718-4111

SCALE: NONE	PROJECT:
DATE: 6/3/04	<p><b>DOUBLE CELL BOX CULVERT TYPE-1 SLOPED END SECTIONS</b></p>
DRN BY: RTF	
REV: 2/2/16 REM	DWG NAME: 1820-10

PROPRIETARY & CONFIDENTIAL: INFORMATION PROVIDED IS THE PROPERTY OF RINKER MATERIALS. UNAUTHORIZED REPRODUCTION IS PROHIBITED.

**PROPOSAL: AS 2024-05 PRE-CAST CONCRETE PIPE AND BRIDGE PRODUCTS**

**RINKER MATERIALS**

PO BOX 1620, RAPID CITY, SD 57709-1620

PRESTRESSED CONCRETE BRIDGE DECK UNITS AND ABUTMENT PLANK

Price FOB PENNINGTON CO.

Length FT.	23" Deep X 3' 10" Wide		30" Deep x 3' 10" Wide		Minimum Rail Post Quantity Per Ext/Span
	Weight LBS	Price EACH	Weight LBS	Price EACH	
20	10100	\$ 3,882.00 *	12300	\$ 4,294.00 *	3
25	12400	\$ 4,534.00	15000	\$ 5,161.00	4
30	14700	\$ 5,399.00	17800	\$ 6,201.00	4
35	17000	\$ 6,434.00	20500	\$ 6,844.00	5
40	19300	\$ 6,938.00	23300	\$ 7,505.00	6
45	21900	\$ 8,026.00	26600	\$ 9,213.00	6
50			29400	\$ 9,857.00	7
55			32200	\$ 10,608.00	7
60			34900	\$ 11,402.00	8
65			37700	\$ 12,134.00	9

**Rail Post Connections** \$138.00

\* The above prices are for interior deck units. Exterior deck prices are \$138.00 times the minimum rail post quantity added to the interior price.

**Bearing Items**

Bonded bearing pads and access., SDDOT design \$278.00  
 Loose bearing pads \$171.00

<b>End Plank 3"</b>	\$	33.00	PSF
---------------------	----	-------	-----

- 1.) If reinforcing steel costs rise over \$1.00/lb., Rinker Materials reserves the right to add a steel surcharge.
- 2.) The above prices are for standard deck units and applicable AASHTO and SDDOT design. See drawing on backside for allowable loading vs span.
- 3.) For non-standard lengths, use the price of the next longer 5' increment.
- 4.) The above prices are for no skew. Add \$163.00 per deck unit for standard skews of 15 degrees or 30 degrees. Special skews on request.
- 5.) Standard units have full depth end diaphragms. Units 45' and longer also have a center diaphragm. Add \$198.00 for each extra diaphragm.

TERMS: NET 30 DAYS



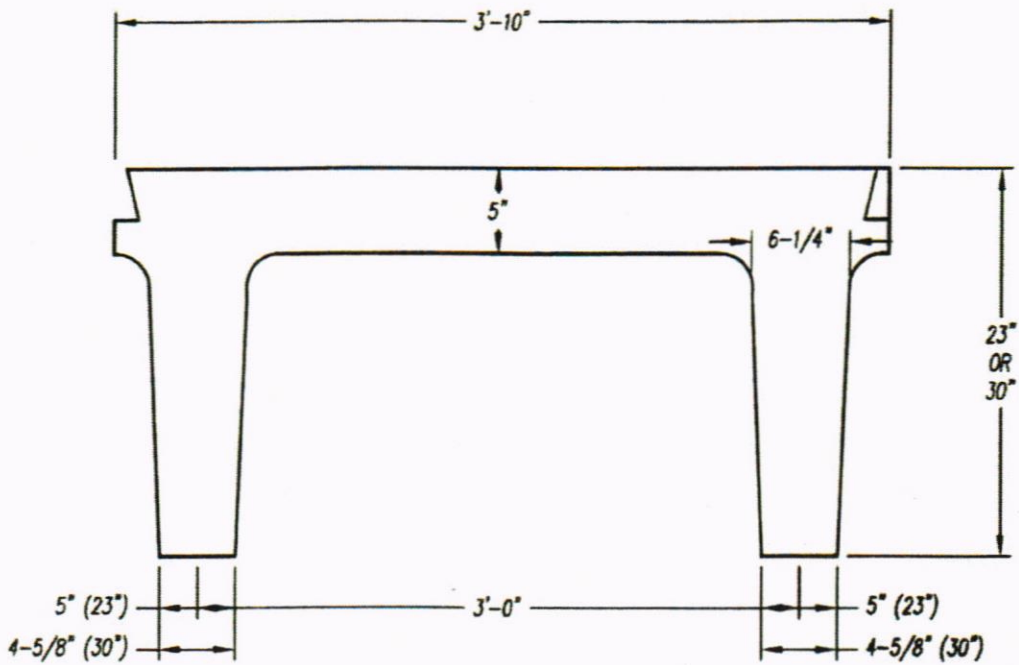

**TYPICAL SECTION VIEW**

SECTION DESIGNATION	23" X 3'-10"	30" X 3'-10"
HEIGHT (in.)	23	30
WIDTH (in.)	46	46
SECTION AREA (in.²)	440	520
I (in.⁴)	19498	42155
Z <sub>x</sub> (in.³)	1279	2162
Z <sub>y</sub> (in.³)	2516	4015
C.G. FROM BOTTOM	15.25	19.5
WEIGHT/FOOT (lbs.)	464.4	548.9
HS20 MAX LENGTH	45	65
HS25 MAX LENGTH	40	55

Above bridge decks are available in spans up to and including those shown. Designs are based on HS20 and Alternate loadings, with a provision for future 22 psf overlay per applicable AASHTO specifications.

Standard designs are available in 5'-0" increments. 30' max skew standard. Larger skews available as special designs.

		Rapid City, South Dakota 4310 Pendleton Drive Rapid City, SD 57701 (605) 718-4111	
		SCALE: NONE	PROJECT:
DATE: 3/12/04	DOUBLE TEE DECK UNITS		
DRN BY: REM			
REV: 2/2/16 REM	DWG NAME: 2020-05		
<small>PROPRIETARY &amp; CONFIDENTIAL: INFORMATION PROVIDED IS THE PROPERTY OF RINKER MATERIALS. UNAUTHORIZED REPRODUCTION IS PROHIBITED.</small>			

AS 2024-05 PRE-CAST CONCRETE PIPE AND BRIDGE PRODUCTS

RINKER MATERIALS

PO BOX 1620, RAPID CITY, SD 57709-1620  
PHONE #: 605-718-4111  
FEDERAL TAX IDENTIFICATION #: 42-0330890

CONTRACT

This agreement made this \_\_\_\_\_ day of \_\_\_\_\_, 20 \_\_\_\_, between PENNINGTON CO. through its Commissioners hereinafter called the *party of the first part* and RINKER MATERIALS, Rapid City, South Dakota or their successors, executors, administrators and assigns, hereafter called the *party of the second part*.

That for and in consideration of payment heretofore mentioned, to be made by the *party of the first part*, the party of the second part agrees to furnish to PENNINGTON CO., RINKER MATERIALS Reinforced Concrete Culvert Pipe, Concrete Bridge Beams and/or other precast concrete products as may be (designed) (ordered) (required), F.O.B. job site as near as possible by trucks. All prices are based on a 48,000 lb. minimum load. Lighter loads may be subject to a freight adjustment.

All delivery agreements contained herein are contingent upon delays due to causes beyond our control.

In consideration of the furnished RINKER MATERIALS products heretofore specified, in compliance herewith, the *party of the first part* agrees to pay the *party of the second part*, the sums of money hereinbefore mentioned in the following manner, to wit:

IN WITNESS WHEREOF, the *parties* hereto have hereunto set their hands and seals on the date first above written.

ATTEST:

COUNTY OF \_\_\_\_\_

by \_\_\_\_\_  
Chairman, Board of County Commissioners  
*Party of the First Part*

\_\_\_\_\_  
County Auditor

RINKER MATERIALS

by  - Area Sales Manager  
*Party of the Second Part*

DATE: February 27, 2024

SUBJECT TO TERMS AND CONDITIONS ON REVERSE SIDE



## STANDARD TERMS AND CONDITIONS

1. **AGREEMENT.** Buyer ("Buyer") and Hydro Conduit, LLC d/b/a Rinker Materials or Forterra Pipe & Precast, LLC d/b/a Rinker Materials, for itself and/or on behalf of one or more of its subsidiaries doing business as Rinker Materials ("Seller") acknowledge, understand and agree that the Buyer's Credit Application, if any, the Quotation, if any, the Order Acknowledgment (the "Acknowledgment"), if any, the specifications stated in the Acknowledgment (or the Quotation if there is no Acknowledgment) and these Standard Terms and Conditions (collectively, the "Agreement") shall collectively form the sole and entire agreement by, under and pursuant to which Buyer shall purchase from Seller, and Seller shall manufacture and sell to Buyer, the materials described in the Acknowledgment (or the Quotation if there is no Acknowledgment) (the "Materials"). This Agreement supersedes any and all prior or contemporaneous oral or written agreements between the parties regarding the same.

Any different or additional terms or conditions contained in Buyer's acceptance of the Quotation and/or the Acknowledgment, or any document or instrument constituting this Agreement, whether by purchase order or otherwise, are hereby objected to by Seller and shall have no effect on, and not become part of, the terms and conditions of this Agreement. Additional terms, changes, and alleged subsequent agreements shall not be effective unless and until any of the same are in writing and signed by Seller's and Buyer's authorized representatives. Notwithstanding any subsequent changes made to the Quotation or the Acknowledgment, these Standard Terms and Conditions (in the form originally referred to or attached to the Quotation or the Acknowledgment, as the case may be) shall continue in full and unvaried force and effect except to the extent modified by written agreement signed by Seller's and Buyer's authorized representatives.

Buyer's signature to the Quotation and/or the Acknowledgment, direction to manufacture the Materials, acceptance of delivery of the Materials or the payment for the Materials shall be deemed an acceptance of these Standard Terms and Conditions. Seller may elect not to manufacture or deliver any Materials until Buyer returns a signed copy of the Quotation and/or the Acknowledgment.

2. **DELIVERY AND ACCEPTANCE.** Delivery of the Materials shall be made pursuant to a delivery schedule agreed to by Buyer and Seller. Seller shall not be deemed to have failed to comply with such schedule for any delay where such delay is caused by acts of God, acts of civil or military authority, epidemics, war, riot, scarcity of labor, raw materials or transportation or any other reason or cause beyond Seller's control. In connection with any such delay, the agreed delivery date(s) shall be extended for a period equal to the duration of the delay.

Seller's responsibility for delivery shall cease FOB shipping point or, if Seller agrees to deliver FOB jobsite, at the curbside or street or frontage of the address of delivery. Seller reserves the right to charge Buyer at the applicable rate for any waiting time at the jobsite in excess of one (1) hour.

The type and quantity of Materials delivered and detailed on the delivery ticket must be inspected by Buyer at the time of delivery for compliance with the Agreement. Variations between actual quantities of Materials delivered and those shown on the delivery ticket must be noted on all copies of the delivery ticket signed by Buyer. Invoice charges will be based on the quantities shown on the delivery ticket.

Title and risk of loss of or damage to each of the Materials shall remain with Seller until delivery of such Materials to the delivery location specified in this Agreement. Buyer hereby grants Seller a first priority security interest in all such Materials until such time as Seller is paid in full all amounts due under this Agreement. Buyer further agrees to execute any and all documents that may be required for Seller to perfect such security interest.

Standard Materials sold under this Agreement may be returned by Buyer for credit only with Seller's prior written consent and only if, in Seller's sole opinion, the Materials to be returned are in re-saleable condition. Seller will deduct from any such credit any and all restocking fees, loading and unloading costs and any costs of repair and delivery costs to and from Buyer's jobsite. Custom-designed and special Materials of other than normal and standard design regularly sold by Seller may not be returned. The Buyer will be liable to pay for any custom-designed or special Materials not taken by the Buyer.

In the event of an inspection of any installed reinforced concrete pipe products, the evaluation and acceptance criteria used shall be in accordance with ASTM C1840 unless otherwise agreed to by Buyer and Seller.

3. **TECHNICAL ASSISTANCE.** In no event shall Seller bear any responsibility for claims arising from technical advice or assistance provided to Buyer. Advice and assistance provided by Seller is for Buyer's guidance only, and Buyer agrees to rely solely on its own architects, engineers and other technical expert.
4. **PRICING AND PAYMENT.** Unless stated otherwise herein, prices for the Materials quoted are subject to material availability and shall remain firm for a period of thirty (30) days after the date of the Acknowledgment (or the Quotation if there is no Acknowledgment); thereafter, prices for the Materials are subject to change by Seller. Prices quoted are based on minimum truckload lots and are subject to increase should Buyer request delivery in lots smaller than truckload. Prices are applicable only to the project specified in the Acknowledgment (or the Quotation if there is no Acknowledgment), are available only to the Buyer, and are only for the quantities stated the Acknowledgment (or the Quotation if there is no Acknowledgment).

Payment terms are net 10th prox., without retention or set-off. Seller will submit invoices to Buyer upon each delivery of Materials pursuant to the Agreement. Buyer's obligation to pay Supplier will not be delayed or conditioned upon installation of the Materials furnished pursuant to the Agreement, Buyer's receipt of payment from any third-party, or any disputes between Buyer and the Owner.

Past due amounts will accrue interest at the rate of eighteen percent (18%) per annum or the maximum rate allowed by law, whichever is less. Should Buyer fail to pay when due any amount payable to Seller under the terms of this Agreement, after ten (10) days written notice without cure, Seller may: (a) make demand upon Buyer for assurances of payment, including but not limited to, requesting immediate payments of all amounts then due and owing to Seller under this Agreement; and/or requesting payment in advance of delivery of all future amounts to become due under this Agreement; (b) suspend future deliveries; (c) file a claim of lien and, if applicable, a claim on bond; (d) terminate this Agreement; or (e) take such other actions as Seller determines are necessary to secure its right to payment.

Seller may exercise the right of set-off under this Agreement as to any sums owed by Seller

and/or its affiliates under any other contract or agreement with Buyer and/or its affiliates. Buyer agrees to pay Seller any and all collection fees, attorneys' fees, and court costs incurred by Seller in collecting any amounts due under this Agreement.

5. **TAXES.** In the absence of an exemption or resale certificate reasonably acceptable to Seller and to the respective taxing authority, all federal, state and local taxes, assessments, fees, duties and charges levied by reason of this Agreement are in addition to the prices set forth in the Acknowledgment and shall be the sole responsibility of, and paid by, Buyer.
6. **LIMITED WARRANTY AND LIABILITY DISCLAIMER.** Seller warrants that the Materials sold under this Agreement shall conform to the specifications as described in the Acknowledgment (or the Quotation if there is no Acknowledgment) and shall be free from defects in manufacturing and workmanship provided Buyer provides written notice of any such non-conformance or defects to Seller within one (1) year from the date of delivery of the Materials. The foregoing warranty is subject to standard manufacturing and color variations, efflorescence, tolerances and classifications. Seller is not responsible for installation or defective conditions caused by installation. Buyer's exclusive remedy for breach of this warranty shall be to require Seller, at Seller's option, to refund the purchase price for the defective or nonconforming Materials sold hereunder or to repair or to replace any defective or nonconforming Materials. Seller shall not be responsible for any removal or installation costs. THE FOREGOING WARRANTY IS IN LIEU OF AND EXCLUDES, AND SELLER HEREBY DISCLAIMS, AND BUYER HEREBY WAIVES, ALL OTHER WARRANTIES, WHETHER WRITTEN, VERBAL, EXPRESS OR IMPLIED, BY LAW OR OTHERWISE, INCLUDING, WITHOUT LIMITATION, ANY IMPLIED WARRANTIES OF FITNESS FOR A PARTICULAR PURPOSE, MERCHANTABILITY OR HABITABILITY. Seller makes no warranty whatsoever with respect to goods, products, accessories or parts furnished by Seller but not manufactured by Seller, which carry only the warranty, if any, in the applicable manufacturer's warranties (if any) to the extent permitted by the terms of such warranty between Seller and such manufacturer.
7. **LIMITATION OF LIABILITY.** Seller's liability on any claim for loss or damage arising from this Agreement, or the fabrication or sale of any of the Materials pursuant to this Agreement, whether based on contract, warranty, tort (including negligence) or other grounds, shall not exceed the price of the Materials actually received from Buyer by Seller under this Agreement with regard to which such claim for loss or damage is made. Neither Seller nor Buyer will be liable to the other party, or any third party beneficiary, whether as a result of breach of contract, warranty, tort (including negligence and strict liability) or other grounds, for special, consequential, incidental, punitive (if allowed by law) or other indirect damages of any kind, including, but not limited to loss of data, loss of profits or revenue, loss of use of the Materials furnished by Seller pursuant to this Agreement or any associated product, cost of capital, cost of substitute products, facilities, services, downtime costs, or claims, or for liquidated damages (delay or otherwise) incurred by such party from any third party.
8. **INDEMNIFICATION.** To the fullest extent permitted by applicable law, each party (the "Indemnifying Party") agrees to indemnify, defend and hold harmless the other party and its affiliated companies along with its respective officers, directors, owners, employees and agents (collectively the "Indemnitees") from and against all claims, damages, losses, liens, causes of action, suits, judgments and expenses (including but not limited to reasonable attorney fees) of any person or entity, to the extent arising out of, any injury, death or destruction of property, but only to the extent caused by or arising from the negligent acts or omission of the Indemnify Party, its employees, any subcontractor, supplier or person or entity over which it controls or exercise control over (collectively, "Claims"); provided, that the Indemnifying Party shall have no obligation to indemnify for any Claims to the extent caused by or arising from the negligence or willful misconduct of any Indemnitee and provided further that "Claims", for purposes hereof, shall not include damages, compensation or benefits payable under any insurance policies, workers' compensation acts, disability benefit acts, or other employees' benefit acts.
- Seller shall indemnify, defend and hold harmless the Indemnitees from and against all claims, damages, losses, liens, causes of action, suits, judgments and expenses (including but not limited to reasonable attorney fees) to the extent arising from any claims made by third parties that the use or sale of the Materials infringes any United States patent covering the Materials. Provided, however, this paragraph will not apply in the event that the infringement results from use of the Materials in combination with other materials, goods, or manufacturing processes.
9. **ASSIGNMENT.** Neither party shall assign this Agreement or any interest herein without the prior written consent of the other party, and any attempted assignment, whether by operation of law or otherwise, shall be void without such prior written consent.
10. **NOTICE.** Any notice required to be sent to Seller shall be in writing and sent by Certified Mail, postage prepaid, to the Seller's office set forth on the Quotation and/or Acknowledgment, with a copy to Seller c/o Rinker Materials, 5 Concourse Parkway, Suite 1900, Atlanta, Georgia 30328, Attention: Legal Department. Any notice required to be sent to Buyer shall be in writing and sent by Certified Mail, postage prepaid, to the Buyer's office set forth on the Quotation and/or Acknowledgment.
11. **SEVERABILITY.** If any term, provision, covenant, or condition of this Agreement is held by a court of competent jurisdiction to be invalid, void, or unenforceable, the remainder of the provisions shall remain in full force and effect and shall in no way be affected, impaired, or invalidated. The parties agree that each term and provision of this Agreement shall be construed according to its fair meaning and not strictly for or against any party.
12. **VENUE AND CHOICE OF LAW.** The parties hereto agree that venue for any action brought for the breach of or the enforcement of this Agreement will lie in the county of the Project site described in the Acknowledgment (or the Quotation if there is no Acknowledgment). This Agreement shall be governed by and shall be construed in accordance with the laws of the state of the Project site described in the Acknowledgment (or the Quotation if there is no Acknowledgment), without regard to its conflicts of law provisions. AS A MATERIAL INDUCEMENT TO ENTER INTO THIS AGREEMENT, BOTH PARTIES WAIVE THE RIGHT TO TRIAL BY JURY IN ANY PROCEEDING ARISING OUT OF OR RELATED TO THIS AGREEMENT.
13. **WAIVER.** Failure or inability of either party to enforce any right hereunder shall not waive any right in respect to any other or future rights or occurrences.
14. **CORRECTIONS.** Seller reserves the right to correct typographical or clerical errors appearing in the Quotation, the Acknowledgment or other documents constituting the Agreement.



# Proposal and / or Contract

## AS 2024-05 PRE-CAST CONCRETE PIPE AND BRIDGE PRODUCTS

**RINKER MATERIALS**  
PO BOX 1620, RAPID CITY, SD 57709-1620

To the Honorable Board of County Commissioners:

We would like to offer you the following prices on our prestressed concrete bulb tee bridge deck as a **separate** quotation for precast prestressed bridge decks. These prices **do not** include freight as do the rest of our precast prestressed bridge decks. Because of the length and weight of these beams, freight costs will vary substantially based upon length of haul and location of jobsite.

We offer you these prices FOB our plant. The total freight charge per bridge site can be provided as an informal quotation at such time as bridge length and location are determined.

### PRESTRESSED CONCRETE BULB TEE BRIDGE DECK UNITS FOB RAPID CITY PLANT

Length	40" Deep X 6'-0" Wide		Minimum Rail Post Quantity
	Weight	Interior Deck Price	
FT.	LBS	EACH	Per Ext/Span
40	38800	\$ 11,338.00	6
45	43700	\$ 12,657.00	7
50	48500	\$ 14,516.00	7
55	53400	\$ 15,894.00	8
60	58200	\$ 17,290.00	8
65	63100	\$ 18,426.00	9
70	67900	\$ 20,110.00	10
75	72800	\$ 21,534.00	10
80	77600	\$ 23,168.00	11
85	82500	\$ 24,921.00	11
90	87300	\$ 26,233.00	12
95	92200	\$ 27,548.00	13
99	96000	\$ 29,073.00	13

Length	40" Deep X 6'-6" Wide		Minimum Rail Post Quantity
	Weight	Interior Deck Price	
FT.	LBS	EACH	Per Ext/Span
40	41400	\$ 11,913.00	6
45	46600	\$ 13,243.00	7
50	51700	\$ 15,147.00	7
55	56900	\$ 16,613.00	8
60	62000	\$ 18,644.00	8
65	67200	\$ 19,803.00	9
70	72400	\$ 21,311.00	10
75	77600	\$ 22,950.00	10
80	82800	\$ 24,264.00	11
85	87900	\$ 25,797.00	11
90	93100	\$ 27,323.00	12
95	98300	\$ 29,073.00	13
99	102400	\$ 30,603.00	13

TERMS: NET 30 DAYS

# Proposal and / or Contract

## AS 2024-05 PRE-CAST CONCRETE PIPE AND BRIDGE PRODUCTS

**RINKER MATERIALS**  
 PO BOX 1620, RAPID CITY, SD 57709-1620

To the Honorable Board of County Commissioners:

We would like to offer you the following prices on our prestressed concrete bulb tee bridge deck as a **separate** quotation for precast prestressed bridge decks. These prices **do not** include freight as do the rest of our precast prestressed bridge decks. Because of the length and weight of these beams, freight costs will vary substantially based upon length of haul and location of jobsite.

We offer you these prices FOB our plant. The total freight charge per bridge site can be provided as an informal quotation at such time as bridge length and location are determined.

### PRESTRESSED CONCRETE BULB TEE BRIDGE DECK UNITS FOB RAPID CITY PLANT

Length	40" Deep X 8'-0" Wide		Minimum Rail Post Quantity
	Weight	Interior Deck Price	
FT.	LBS	EACH	Per Ext/Span
40	51600	\$ 13,599.00	6
45	58100	\$ 14,996.00	7
50	64600	\$ 17,226.00	7
55	71000	\$ 18,910.00	8
60	77500	\$ 20,856.00	8
65	84000	\$ 22,734.00	9
70	90400	\$ 24,702.00	10
75	96800	\$ 26,670.00	10
80	103300	\$ 28,422.00	11
85	109800	\$ 30,166.00	11
90	116200	\$ 32,131.00	12

**T- 101 Rail Post Connections** \$ 163.00 per connection

\* The above prices are for interior deck units. Exterior deck prices are \$ 163.00 times the minimum rail post quantity added to the interior price. The T-101 rail post connection is the only style available. The required bolts are not included.

**Bearing Items**

Loose bearing pads \$ 310.00 per deck unit

**Diaphragms**

Sleeves are cast in beams at midspan and at beam ends to accept either steel or cast in place diaphragms.

- 1.) If reinforcing steel costs rise over \$1.00/lb., Rinker Materials reserves the right to add a steel surcharge.
- 2.) The above prices are for standard deck units designed per AASHTO and DOT requirements. See drawing on backside for allowable loading vs span.
- 3.) For non-standard lengths, use the price of the next longer 5' increment.
- 4.) The above prices are for no skew. Contact Rapid City Office if skew is required or for freight arrangements.

**TERMS: NET 30 DAYS**



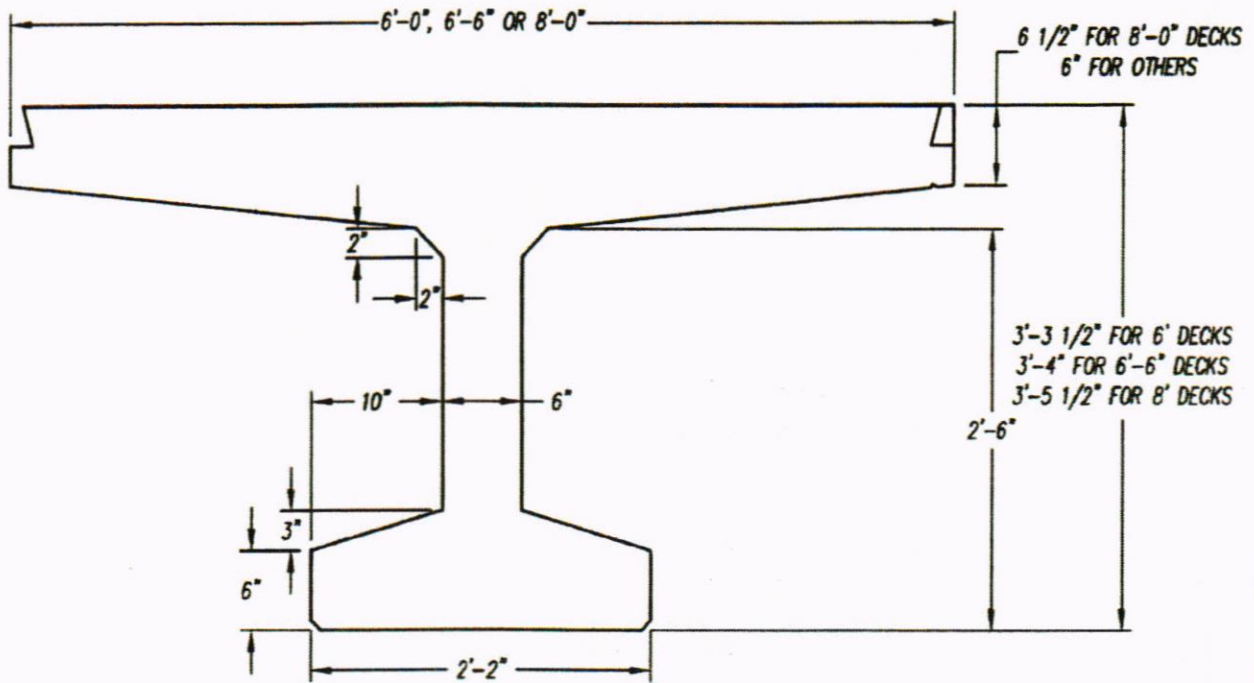

SECTION DESIGNATION	30-6	30-6.5	30-8
HEIGHT (in.)	39.5	40	41.5
WIDTH (in.)	72	78	96
SECTION AREA (in. <sup>2</sup> )	917	980	1223
I (in. <sup>4</sup> )	166354	174734	205161
Z <sub>x</sub> (in. <sup>3</sup> )	6325	6472	6955
Z <sub>y</sub> (in. <sup>3</sup> )	12603	13441	17097
C.G. FROM BOTTOM	26.3	27.0	29.5
WEIGHT/FOOT (lbs.)	956	1021	1274
HS20 MAX LENGTH	**	**	**
HS25 MAX LENGTH	**	**	**

\*\* CONTACT FORTERRA PIPE AND PRECAST

		Rapid City, South Dakota 4310 Pendleton Drive Rapid City, SD 57701 (605) 718-4111	
		SCALE: NONE	PROJECT:
DATE: 2/24/05	DECK BULB TEE		
DR'N BY: RTF			
REV: 2/2/16 REM	DWG NAME:	2010-05	
<small>PROPRIETARY &amp; CONFIDENTIAL: INFORMATION PROVIDED IS THE PROPERTY OF RINKER MATERIALS. UNAUTHORIZED REPRODUCTION IS PROHIBITED.</small>			

AS 2024-05 PRE-CAST CONCRETE PIPE AND BRIDGE PRODUCTS

RINKER MATERIALS
PO BOX 1620, RAPID CITY, SD 57709-1620
PHONE #: 605-718-4111
FEDERAL TAX IDENTIFICATION #: 42-0330890

PRESTRESSED CONCRETE BULB TEE BRIDGE DECK
C O N T R A C T

This agreement made this \_\_\_\_\_ day of \_\_\_\_\_, 20 \_\_\_\_, between PENNINGTON CO. through its Commissioners hereinafter called the party of the first part and RINKER MATERIALS, Rapid City, South Dakota or their successors, executors, administrators and assigns, hereafter called the party of the second part.

That for and in consideration of payment heretofore mentioned, to be made by the party of the first part, the party of the second part agrees to furnish to PENNINGTON CO., RINKER MATERIALS Prestressed Concrete Bulb Tee Bridge Decks as may be required, F.O.B. Rapid City plant site. The total freight per bridge site can be provided as an informal quotation at such time as bridge length and location are determined.

In consideration of the furnished RINKER MATERIALS products heretofore specified, in compliance herewith, the party of the first part agrees to pay the party of the second part, the sums of money hereinbefore mentioned in the following manner, to wit:

IN WITNESS WHEREOF, the parties hereto have hereunto set their hands and seals on the date first above written.

ATTEST:

COUNTY OF \_\_\_\_\_

\_\_\_\_\_  
County Auditor

by \_\_\_\_\_  
Chairman, Board of County Commissioners  
Party of the First Part

RINKER MATERIALS

by  - Area Sales Manager  
Party of the Second Part

DATE: February 27, 2024

SUBJECT TO TERMS AND CONDITIONS ON REVERSE SIDE



## STANDARD TERMS AND CONDITIONS

1. **AGREEMENT.** Buyer ("Buyer") and Hydro Conduit, LLC d/b/a Rinker Materials or Forterra Pipe & Precast, LLC d/b/a Rinker Materials, for itself and/or on behalf of one or more of its subsidiaries doing business as Rinker Materials ("Seller") acknowledge, understand and agree that the Buyer's Credit Application, if any, the Quotation, if any, the Order Acknowledgment (the "Acknowledgment"), if any, the specifications stated in the Acknowledgment (or the Quotation if there is no Acknowledgment) and these Standard Terms and Conditions (collectively, the "Agreement") shall collectively form the sole and entire agreement by, under and pursuant to which Buyer shall purchase from Seller, and Seller shall manufacture and sell to Buyer, the materials described in the Acknowledgment (or the Quotation if there is no Acknowledgment) (the "Materials"). This Agreement supersedes any and all prior or contemporaneous oral or written agreements between the parties regarding the same.

Any different or additional terms or conditions contained in Buyer's acceptance of the Quotation and/or the Acknowledgment, or any document or instrument constituting this Agreement, whether by purchase order or otherwise, are hereby objected to by Seller and shall have no effect on, and not become part of, the terms and conditions of this Agreement. Additional terms, changes, and alleged subsequent agreements shall not be effective unless and until any of the same are in writing and signed by Seller's and Buyer's authorized representatives. Notwithstanding any subsequent changes made to the Quotation or the Acknowledgment, these Standard Terms and Conditions (in the form originally referred to or attached to the Quotation or the Acknowledgment, as the case may be) shall continue in full and unvaried force and effect except to the extent modified by written agreement signed by Seller's and Buyer's authorized representatives.

Buyer's signature to the Quotation and/or the Acknowledgment, direction to manufacture the Materials, acceptance of delivery of the Materials or the payment for the Materials shall be deemed an acceptance of these Standard Terms and Conditions. Seller may elect not to manufacture or deliver any Materials until Buyer returns a signed copy of the Quotation and/or the Acknowledgment.

2. **DELIVERY AND ACCEPTANCE.** Delivery of the Materials shall be made pursuant to a delivery schedule agreed to by Buyer and Seller. Seller shall not be deemed to have failed to comply with such schedule for any delay where such delay is caused by acts of God, acts of civil or military authority, epidemics, war, riot, scarcity of labor, raw materials or transportation or any other reason or cause beyond Seller's control. In connection with any such delay, the agreed delivery date(s) shall be extended for a period equal to the duration of the delay.

Seller's responsibility for delivery shall cease FOB shipping point or, if Seller agrees to deliver FOB jobsite, at the curbside or street or frontage of the address of delivery. Seller reserves the right to charge Buyer at the applicable rate for any waiting time at the jobsite in excess of one (1) hour.

The type and quantity of Materials delivered and detailed on the delivery ticket must be inspected by Buyer at the time of delivery for compliance with the Agreement. Variations between actual quantities of Materials delivered and those shown on the delivery ticket must be noted on all copies of the delivery ticket signed by Buyer. Invoice charges will be based on the quantities shown on the delivery ticket.

Title and risk of loss of or damage to each of the Materials shall remain with Seller until delivery of such Materials to the delivery location specified in this Agreement. Buyer hereby grants Seller a first priority security interest in all such Materials until such time as Seller is paid in full all amounts due under this Agreement. Buyer further agrees to execute any and all documents that may be required for Seller to perfect such security interest.

Standard Materials sold under this Agreement may be returned by Buyer for credit only with Seller's prior written consent and only if, in Seller's sole opinion, the Materials to be returned are in re-saleable condition. Seller will deduct from any such credit any and all restocking fees, loading and unloading costs and any costs of repair and delivery costs to and from Buyer's jobsite. Custom-designed and special Materials of other than normal and standard design regularly sold by Seller may not be returned. The Buyer will be liable to pay for any custom-designed or special Materials not taken by the Buyer.

In the event of an inspection of any installed reinforced concrete pipe products, the evaluation and acceptance criteria used shall be in accordance with ASTM C1840 unless otherwise agreed to by Buyer and Seller.

3. **TECHNICAL ASSISTANCE.** In no event shall Seller bear any responsibility for claims arising from technical advice or assistance provided to Buyer. Advice and assistance provided by Seller is for Buyer's guidance only, and Buyer agrees to rely solely on its own architects, engineers and other technical expert.
4. **PRICING AND PAYMENT.** Unless stated otherwise herein, prices for the Materials quoted are subject to material availability and shall remain firm for a period of thirty (30) days after the date of the Acknowledgment (or the Quotation if there is no Acknowledgment); thereafter, prices for the Materials are subject to change by Seller. Prices quoted are based on minimum truckload lots and are subject to increase should Buyer request delivery in lots smaller than truckload. Prices are applicable only to the project specified in the Acknowledgment (or the Quotation if there is no Acknowledgment), are available only to the Buyer, and are only for the quantities stated in the Acknowledgment (or the Quotation if there is no Acknowledgment).

Payment terms are net 10th prox., without retention or set-off. Seller will submit invoices to Buyer upon each delivery of Materials pursuant to the Agreement. Buyer's obligation to pay Supplier will not be delayed or conditioned upon installation of the Materials furnished pursuant to the Agreement, Buyer's receipt of payment from any third-party, or any disputes between Buyer and the Owner.

Past due amounts will accrue interest at the rate of eighteen percent (18%) per annum or the maximum rate allowed by law, whichever is less. Should Buyer fail to pay when due any amount payable to Seller under the terms of this Agreement, after ten (10) days written notice without cure, Seller may: (a) make demand upon Buyer for assurances of payment, including but not limited to, requesting immediate payments of all amounts then due and owing to Seller under this Agreement; and/or requesting payment in advance of delivery of all future amounts to become due under this Agreement; (b) suspend future deliveries; (c) file a claim of lien and, if applicable, a claim on bond; (d) terminate this Agreement; or (e) take such other actions as Seller determines are necessary to secure its right to payment.

Seller may exercise the right of set-off under this Agreement as to any sums owed by Seller

and/or its affiliates under any other contract or agreement with Buyer and/or its affiliates. Buyer agrees to pay Seller any and all collection fees, attorneys' fees, and court costs incurred by Seller in collecting any amounts due under this Agreement.

5. **TAXES.** In the absence of an exemption or resale certificate reasonably acceptable to Seller and to the respective taxing authority, all federal, state and local taxes, assessments, fees, duties and charges levied by reason of this Agreement are in addition to the prices set forth in the Acknowledgment and shall be the sole responsibility of, and paid by, Buyer.
6. **LIMITED WARRANTY AND LIABILITY DISCLAIMER.** Seller warrants that the Materials sold under this Agreement shall conform to the specifications as described in the Acknowledgment (or the Quotation if there is no Acknowledgment) and shall be free from defects in manufacturing and workmanship provided Buyer provides written notice of any such non-conformance or defects to Seller within one (1) year from the date of delivery of the Materials. The foregoing warranty is subject to standard manufacturing and color variations, efflorescence, tolerances and classifications. Seller is not responsible for installation or defective conditions caused by installation. Buyer's exclusive remedy for breach of this warranty shall be to require Seller, at Seller's option, to refund the purchase price for the defective or nonconforming Materials sold hereunder or to repair or to replace any defective or nonconforming Materials. Seller shall not be responsible for any removal or installation costs. THE FOREGOING WARRANTY IS IN LIEU OF AND EXCLUDES, AND SELLER HEREBY DISCLAIMS, AND BUYER HEREBY WAIVES, ALL OTHER WARRANTIES, WHETHER WRITTEN, VERBAL, EXPRESS OR IMPLIED, BY LAW OR OTHERWISE, INCLUDING, WITHOUT LIMITATION, ANY IMPLIED WARRANTIES OF FITNESS FOR A PARTICULAR PURPOSE, MERCHANTABILITY OR HABITABILITY. Seller makes no warranty whatsoever with respect to goods, products, accessories or parts furnished by Seller but not manufactured by Seller, which carry only the warranty, if any, in the applicable manufacturer's warranties (if any) to the extent permitted by the terms of such warranty between Seller and such manufacturer.
7. **LIMITATION OF LIABILITY.** Seller's liability on any claim for loss or damage arising from this Agreement, or the fabrication or sale of any of the Materials pursuant to this Agreement, whether based on contract, warranty, tort (including negligence) or other grounds, shall not exceed the price of the Materials actually received from Buyer by Seller under this Agreement with regard to which such claim for loss or damage is made. Neither Seller nor Buyer will be liable to the other party, or any third party beneficiary, whether as a result of breach of contract, warranty, tort (including negligence and strict liability) or other grounds, for special, consequential, incidental, punitive (if allowed by law) or other indirect damages of any kind, including, but not limited to loss of data, loss of profits or revenue, loss of use of the Materials furnished by Seller pursuant to this Agreement or any associated product, cost of capital, cost of substitute products, facilities, services, downtime costs, or claims, or for liquidated damages (delay or otherwise) incurred by such party from any third party.
8. **INDEMNIFICATION.** To the fullest extent permitted by applicable law, each party (the "Indemnifying Party") agrees to indemnify, defend and hold harmless the other party and its affiliated companies along with its respective officers, directors, owners, employees and agents (collectively the "Indemnitees") from and against all claims, damages, losses, liens, causes of action, suits, judgments and expenses (including but not limited to reasonable attorney fees) of any person or entity, to the extent arising out of, or any injury, death or destruction of property, but only to the extent caused by or arising from the negligent acts or omission of the Indemnity Party, its employees, any subcontractor, supplier or person or entity over which it controls or exercise control over (collectively, "Claims"); provided, that the Indemnifying Party shall have no obligation to indemnify for any Claims to the extent caused by or arising from the negligence or willful misconduct of any Indemnitee and provided further that "Claims", for purposes hereof, shall not include damages, compensation or benefits payable under any insurance policies, workers' compensation acts, disability benefit acts, or other employees' benefit acts.
- Seller shall indemnify, defend and hold harmless the Indemnitees from and against all claims, damages, losses, liens, causes of action, suits, judgments and expenses (including but not limited to reasonable attorney fees) to the extent arising from any claims made by third parties that the use or sale of the Materials infringes any United States patent covering the Materials. Provided, however, this paragraph will not apply in the event that the infringement results from use of the Materials in combination with other materials, goods, or manufacturing processes.
9. **ASSIGNMENT.** Neither party shall assign this Agreement or any interest herein without the prior written consent of the other party, and any attempted assignment, whether by operation of law or otherwise, shall be void without such prior written consent.
10. **NOTICE.** Any notice required to be sent to Seller shall be in writing and sent by Certified Mail, postage prepaid, to the Seller's office set forth on the Quotation and/or Acknowledgment, with a copy to Seller c/o Rinker Materials, 5 Concourse Parkway, Suite 1900, Atlanta, Georgia 30328, Attention: Legal Department. Any notice required to be sent to Buyer shall be in writing and sent by Certified Mail, postage prepaid, to the Buyer's office set forth on the Quotation and/or Acknowledgment.
11. **SEVERABILITY.** If any term, provision, covenant, or condition of this Agreement is held by a court of competent jurisdiction to be invalid, void, or unenforceable, the remainder of the provisions shall remain in full force and effect and shall in no way be affected, impaired, or invalidated. The parties agree that each term and provision of this Agreement shall be construed according to its fair meaning and not strictly for or against any party.
12. **VENUE AND CHOICE OF LAW.** The parties hereto agree that venue for any action brought for the breach of or the enforcement of this Agreement will lie in the county of the Project site described in the Acknowledgment (or the Quotation if there is no Acknowledgment). This Agreement shall be governed by and shall be construed in accordance with the laws of the state of the Project site described in the Acknowledgment (or the Quotation if there is no Acknowledgment), without regard to its conflicts of law provisions. AS A MATERIAL INDUCEMENT TO ENTER INTO THIS AGREEMENT, BOTH PARTIES WAIVE THE RIGHT TO TRIAL BY JURY IN ANY PROCEEDING ARISING OUT OF OR RELATED TO THIS AGREEMENT.
13. **WAIVER.** Failure or inability of either party to enforce any right hereunder shall not waive any right in respect to any other or future rights or occurrences.
14. **CORRECTIONS.** Seller reserves the right to correct typographical or clerical errors appearing in the Quotation, the Acknowledgment or other documents constituting the Agreement.